

Foot Rest

Model: CM-FR110

Desc: Foot rest

Size: 6" x 6"

Thickness: 12.5"

Material: Cast marble

Finish: Gloss or Matt

Brand: NERVAL

Limited Lifetime Warranty

Features:

- Foot rest
- Smooth finish
- Sealed surface
- No mold or mildew
- Easy to install

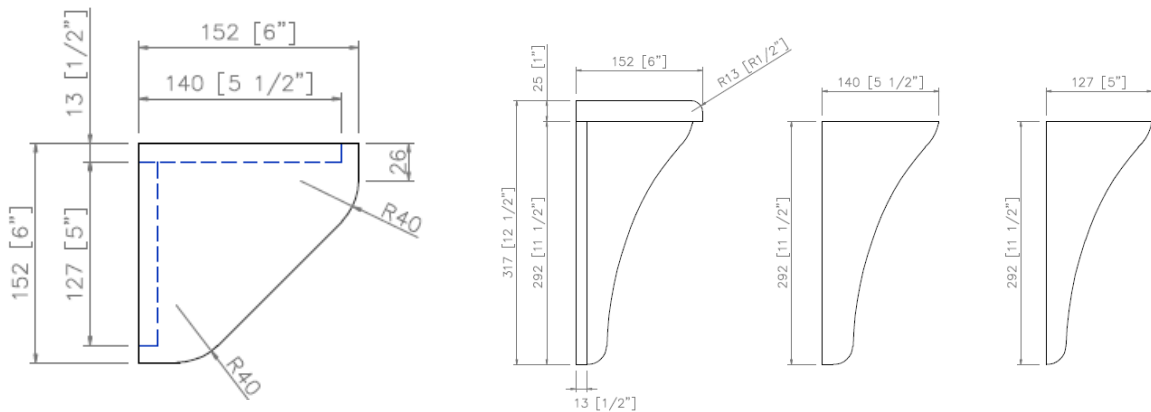

Disclaimer: Nerval makes every effort to provide accurate specification data. However, specification may change without notice. Please visit nerval website to see NERVAL'S TERMS AND CONDITIONS.